



These warning sphere markers are compliant with International Civil Aviation Organization (ICAO) recommendations annex 14 chapter 6.

A marker displayed on an overhead wire, cable etc. should be spherical and not have a diameter of not less than 600mm

A marker should be of one colour. When installed, white and red, or white and orange markers should be displayed alternately. The colour selected should contrast with the background against it will be seen.

The spacing between two consecutive markers or between a marker and a transmission tower should be appropriate to the diameter of the marker, but in no case should the spacing exceed 30 meters when the marker diameter is 60 cm.



- Diameter: 600mm
- Material: Fibre Glass Reinforced
- Colour: Orange Aviation
- Clamps: Aluminium Alloy adapted to the diameter of the cable
- Strong Vibration Resistance
- Rotation Resistance
- Sliding Resistance
- Rain Water Drainage System

TECHNICAL SPECIFICATIONS

Optional colour	Orange aviation / Red / White
Material	Reinforced fibre glass
Diameter	600mm

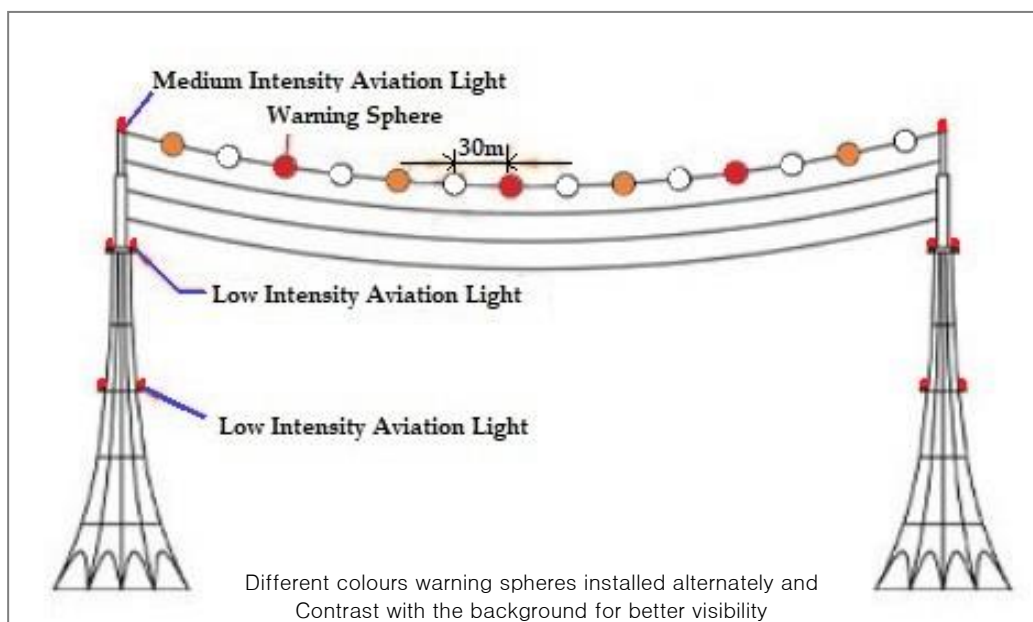



DIMENSIONS

Overall size (mm)	630mm×700mm×600mm
Dimension of cable	8.8mm up to 16mm
Weight	6.3 kg

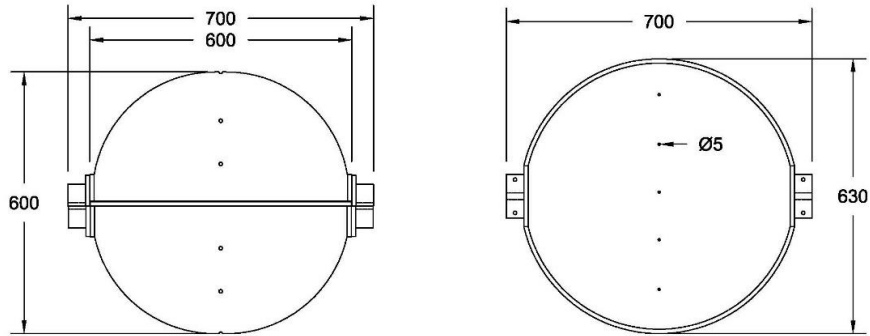

ORDERING CODE

Reference	Colour
EWS600 – O	Orange
EWS600 – R	Red
EWS600 – W	White
EWS600 – RW	Red / White
EWS600 – OW	Orange / White

